

MACHINE METHODS OF ACCOUNTING

ELECTRIC TABULATING MACHINES

JUST as the original tabulator was especially designed by Dr. Hollerith to effect an accurate and rapid means of obtaining desired information concerning the 1890 Census, so the modern International Electric Accounting Machines have been especially designed to meet the demands of the modern executive for varied as well as timely and accurate information concerning his business. Wasteful and costly practices for which remedial measures should be established are exposed and profitable activities which would otherwise be overlooked and neglected are quickly revealed through the frequent use of brief summarizations and detailed analyses of current activities. The electric accounting machines are especially adaptable also to furnishing comparative totals according to various controllable classifications.

The importance which the phase of accounting, concerned with the preparation of summarizations of like transactions, has assumed in modern business has already been briefly discussed. Of special importance is the recognition of the fact that this is the problem for which tabulating cards and machines were primarily developed. It is even more significant, however, in reviewing the improvements in punched card equipment to recognize the emphasis which has been placed on the development of means to perform automatically many of the essential operations and to omit entirely the time-consuming operations which are indispensable steps in other routines. The preparation of complete final reports and documents by a procedure which eliminates entirely the necessity for tedi-

ously posting intermediate records and checking details, is a distinctive feature of the punched card method.

Distinctive Features

Unit records in the form of punched tabulating cards are fed at the rate of 150 a minute through the machine, and in the course of their passage serve to actuate various adding counters in which gross and net amounts are accumulated.

A group sensing device, known as the Automatic Control, compares the punched classification field of each card fed into the machine with that of the one which preceded it, and stops the machine electrically whenever the classification punching in two successive cards differs. The stopping of the machine indicates that the data appearing on the last card of a group have been introduced into the counters and that the data appearing on the next card will be the first of the succeeding group. The feeding of cards is temporarily suspended to permit the machine to print automatically the group code and totals, clear the amounts from the counters (allowing the next group's addition to begin at zero) and space the printed final report so that the following group totals may appear on the next line.

The control mechanism is supplemented by a counter clearing control which effects the clearing of the sub-totals in some counters and the retention of major totals in others according to certain group classifications. All totals are automatically printed and cleared from the counters.

MATERIAL RECORD								
PLANT NO. <u>3</u>				MONTH OF <u>July</u> 19 <u>3</u>				
MATERIAL		MAXIMA	MINIMA	RECEIPTS	DISBURSEMENTS	QUANTITY BALANCE	AMOUNT BALANCE	
CLASS	ITEM							
20	101	4000	2000	250	1280	2340	247	16
20	102	800	500	127	342	702	7	425
20	103	1000	600		841	257	10	419
20	104	200	50	55	129	243	12	637
24	201	6000	2200	476	3152	3105	49	108
24	203	4500	2000	1507	1680	2219	30	416
24	206	250	85		128	131	8	165
24	208	1250	500	250		550	13	976
26	304	400	180		194	346	12	643
26	306	800	600	107	520	320	21	021
26	307	1000	750		348	533	3	419
27	350	1500	1000	500	410	1250	6	2500
27	351	200	100	50	82	124	6	452
27	354	600	420	144	236	480	4	6325
27	357	1000	600		424	250	2	500
27	358	1000	600	50	625	950	1	5438
28	423	850	400	100	532	410	8	2000

EXPENSE MATERIAL DISTRIBUTION						
PLANT NO. <u>4</u>			PERIOD ENDING <u>June 30</u> 193			
DEPT	ACCOUNT	BUDGET AMOUNT	ACTUAL AMOUNT	VARIANCE		DEPARTMENTAL TOTAL ACTUAL
				OVER	UNDER	
10	120	4050 50	3847 25			
10	121	1210 00	1215 30	5 30		
10	123	2140 60	2103 63		36 97	
10	126	950 00	950 00			
10	134	350 00	512 00	162 00		
						8167 38
12	120	4500 00	455 26	52 6		
12	123	3200 00	3200 00			
12	124	12500 00	10514 7		1985 3	
12	134	220 00	220 00			
12	244	1500 00	1255 2		24 48	
						1974 25

This same principle has been applied to permit the further subdivision of sub-classifications so that a report may be automatically prepared with grand, major, intermediate, and minor totals.

Varying capacities up to eighty-eight characters may be printed simultaneously on a single horizontal line from each card, depending upon the type of construction and the size of the printing unit. This permits the recording of

COUNTER 1			COUNTER 2	COUNTER 3	COUNTER 4	COUNTER 5
BRANCH	SALES-MEN	COMMODITIES	COMMODITY TOTALS	SALESMAN TOTALS	BRANCH TOTALS	GRAND TOTAL
1	32	001	873			
1	32	002	903			
1	32	003	1034	2810 *		
1	33	001	3348			
1	33	002	630			
1	33	003	1789			
1	33	004	823			
1	33	005	654	7244 *		
1	34	001	1754			
1	34	002	768			
1	34	003	985	3507 *	13561 *	

A switch controls the operation of the printing unit. Totals only may be printed, or the printing mechanism may be set to list all the punched data appearing on each tabulating card at a rate of 70 to 120 cards (or lines of the report) a minute. This printing may be either a completely alphabetical description or simply numerical designations. Desired totals, similar to those described above, are automatically printed after information from all cards of a group has been listed.

more than 125 characters a second if the maximum capacity of the machine is utilized. The significance of this speed in the listing of data on Electric Accounting Machines can be realized by contrasting it with the speeds attained by less automatic methods of recording. The average person can write three characters a second with a pen or pencil, and the speed of highly proficient typists is only twelve to thirteen key depressions a second.

INVOICE REGISTER						
						ENTRY DATE <u>March 15</u>
INVOICE NO.	VENDOR	VENDOR NO	INVOICE DATE	GROSS	DISCOUNT	NET
1001	A J HENDERSON AND SONS	1261	1 15	17500	1750	15750
1002	MARSHALL AND SMITH CO	1329	1 16	25700	2570	23130
1003	SMITH THOMAS AND CO	1534	1 10	19325	1932	17393

Historical Development of Tabulating Machines

Important as each of these many features is, it is significant that each one of them constituted an improvement of, or attachment to, a machine that had previously been the most "up to date" model. The rapidity with which obsolescence can and does occur may be perceived readily from the following illustrated historical development of the Accounting Machine.

The Census Tabulator

The first tabulator, developed by Dr. Hollerith, was a simple counting device which moved a pointer one position on a dial each time an electrical circuit was closed through a punched hole corresponding to a predetermined position of the card. This necessitated the incorporation of one clock-like counter for each position of the card to be recorded.

Each counter was actuated by the operation of an electromagnet situated behind its dial. The units pointer moved one position each time the armature was attracted.

The circuit which served to energize the elec-

tromagnet was closed by means of a hand operated press. The bed of the press was composed of a series of mercury-filled cups, while the upper and movable portion consisted of a series of pins which would drop through punched holes of the card into the mercury cups to complete the electrical circuit.

The operation of the machine was almost entirely manual. It was necessary for the operator to place a card in the bed of the press, pull down the lever of the press and, after the completion of registration, remove the card to permit the manual feeding of the next one.

The Integrating Machine

Demands for commercial applications of the punched hole method of accounting necessitated the development of a regular adding counter that could be used for the accumulation of quantities and values in contrast to the tally operation of the Census Tabulator. When a machine with these improvements made its appearance it was called the Integrating Tabulator.



Census Tabulator



Integrating Tabulator

This machine resembled its predecessor in most respects. The chief difference was in the mechanism of its counters.

Each counter unit of the Integrating Tabulator was so incorporated within the machine that the nine wheels, driven by a mechanism actuated by the punched tabulating card, were visible under a counter window. Amounts as large as eight digits could be introduced directly into a counter from punched holes in the card. The last position at the left was used for accumulating the carry-over of 1's from the adjoining direct adding position.

As each card was fed into the machine, the closing of the electrical circuit added the amount recorded in that card to the total already accumulated from the preceding cards.

Automatic Card Feeding

Shortly after its appearance, the Integrating Machine was improved by the addition of an automatic feed. The hand-operated press permitted the tabulating of only 50 to 80 cards a minute by an experienced operator while the machine with the automatic card-feeding mechanism operated at a speed in excess of 150 cards a minute.

In this machine the cards were started down from the magazine by picker-knives mounted on a reciprocating cross-head which moved vertically. The cards were fed by rollers to a position where small wire brushes and a brass contact roll, instead of pins and mercury filled cups, completed circuits through the punched holes. This change made possible the continuous and uninterrupted feeding of cards into the machine at a uniform rate of speed.

Automatic feeding and tabulating were accomplished by the use of a drive motor which was controlled by a start and a stop key located on the front of the machine, conveniently near the card magazine and stacker. The depression of the start key caused the motor to turn a shaft of the machine which fed the first card. Subsequent cards fed automatically until the last card was added. If for any reason the machine had to be stopped, the stop was effected by means of a stop key which cut off the electrical current from the drive motor.

Stopping at predetermined intervals in a pack of cards—such as at the end of group classifications—was effected by the use of stop cards. Stop cards are similar in dimensions to tabulating cards, but have a section about $\frac{3}{4}$ " in

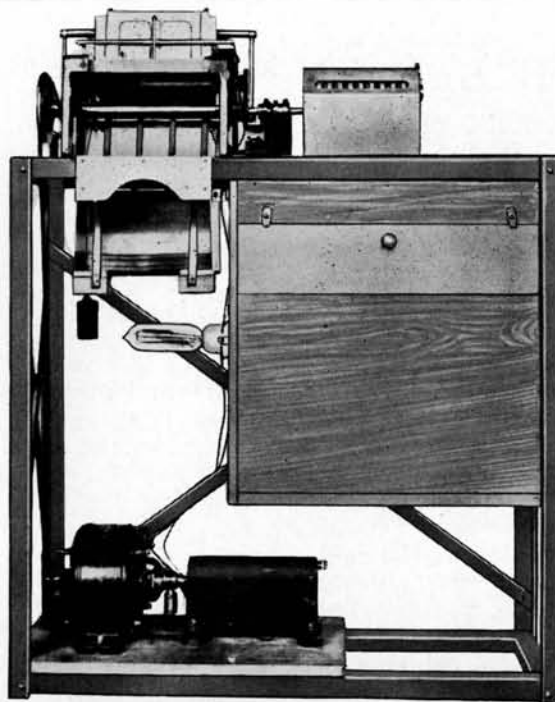

First Automatic Feed Tabulator

width and $1\frac{1}{2}$ " vertically cut off of a lower corner of the card. A small lever located in the feed of the machine was so arranged that whenever a stop card entered the machine, the cut-out portion permitted the lever to move as though no card had been fed. The automatic feeding was thereby stopped in the same manner as though the last card from the magazine had been fed through the machine. It was necessary then to depress the start key in order to restart the machine.

Setup

The machine was especially constructed for the particular type of work it was to perform. Brushes for individual card columns were permanently wired to predetermined positions of the counters in which the accumulations were to appear.

A mechanically operated relay unit was soon developed to increase the variety of applications to which the machine could be adopted. The change in a setup to vary the columns of the card to be added in specified counters was effected by moving a mechanical switch. This switch closed certain of the required internal circuits and opened others which were not to be used in the tabulation. This method was later superseded and became obsolete.

Although many changes have occurred in the course of the development of modern electric bookkeeping and accounting machines, the basic principles embodied in the operation of these machines have remained practically unchanged as evidenced by the following descriptions of current models.

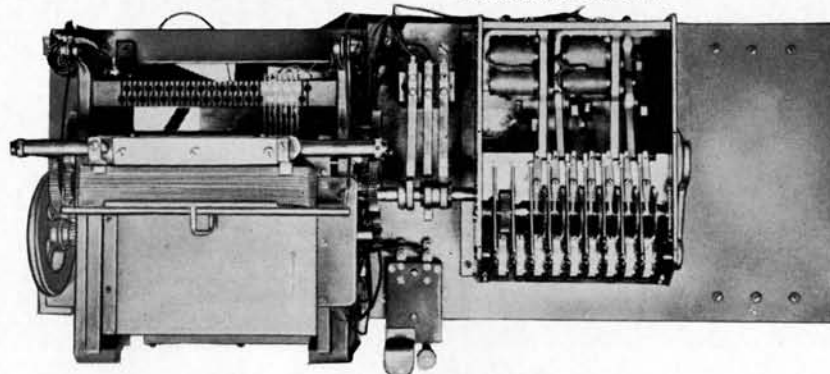

Top View—Automatic Feed Tabulator

Electric Tabulating Machine (Type 92)

Two major steps in the evolution of electric accounting machines resulted in the development of a machine which meets the demand for an auxiliary machine in many present-day installations of the tabulating method.

Among the limitations of the early tabulating machines was its inflexibility—or its limited number of uses because of the permanent wiring of the machine for a few particular types of work. The solution to this problem appeared when the principle of the telephone switchboard was incorporated. Any electrically controlled device such as the tabulator can be controlled through the use of a plugboard and readily removable or interchangeable wires.

The first plugboard was mounted on the rear of the base of the machine. It was shortly thereafter changed to the front position for convenience. The plugboard contains a series of hubs corresponding to the card columns in which data to be tabulated are recorded, and a series of hubs for each counter. By this means, a wire may be inserted (or removed) to control the operation of any position of any counter from any column of the card.

The other major improvement was the incorporation of a more effective counter-clearing

mechanism. The early model of the electric tabulating machine was equipped with a shaft to which each counter could be engaged by means of a collar clutch. Whenever the shaft was turned by means of a hand-operated crank, all engaged counters were reset to 0.

This operation was simplified by the use of a special reset motor governed by an operating key on the front of the machine next to the start and stop keys. The depression of this reset key resulted in the reset shaft being turned by the reset motor. This eliminated the necessity for employing the older method of cranking.

The consolidation of these automatic features resulted in the construction of a machine which is capable of indicating a group code and corresponding totals in any desired counters of the machine. The counters, in which any particular data appear, may be rewired at will by the simple operation of changing the plugboard wires to attain the desired result. Any punched data appearing in any field of a tabulating card may be accumulated in one or more counters which function as simultaneously operated individual adding machines at a speed of 150 cards a minute.

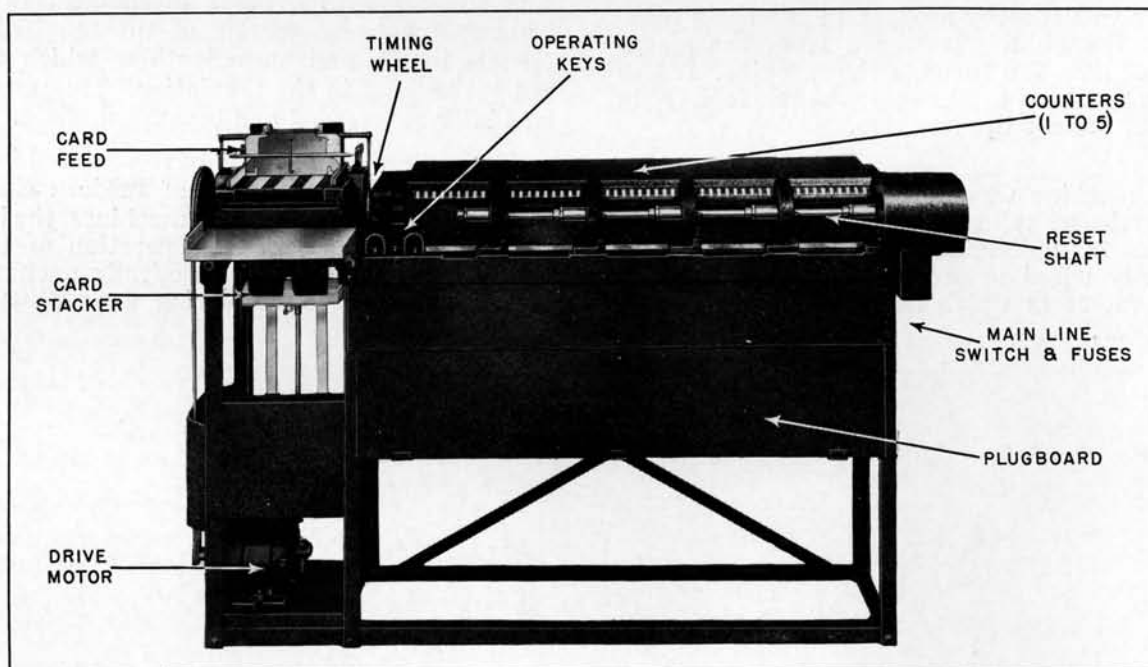

Electric Tabulating Machine—Type 92

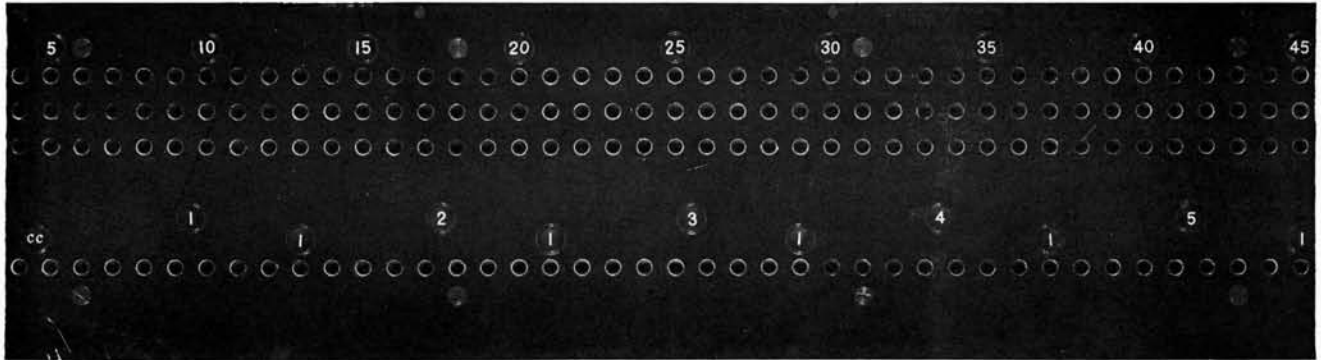

Type 92 Plugboard

The machine may be obtained in two sizes—three or five counters. Each of the counters is a standard unit having eight direct adding positions and a ninth wheel for accumulation of carry-over 1's. The counters are all mounted horizontally on the base in such a position that the data registered in them are readily readable by an operator seated in front of the machine. The attached writing table is conveniently located for use in transcribing counter totals.

Plugboard

The plugboard is a special panel which provides outlets whereby each brush position of the hole-sensing unit in the feed may be connected with counter magnets. It furnishes a means of accomplishing any desired variation of the results of the tabulating operation by the use of readily movable wire connections.

On the plugboard of the machine are three rows of numbered hubs, corresponding to the

columns on the card. Below these are several groups (as many as counters) of hubs, numbered to correspond with the eight adding positions in each counter. The hubs of each counter group are connected internally to the wheels in each of the counters. When data appearing in a field are to be added, the numbers of the columns in the field should first be noted, then the hubs representing those columns should be connected by plug wires to the hubs corresponding to the counter in which the data are to be added. By utilizing the second and third rows of hubs representing the columns on the card, information recorded in the same field can be added in three different counters at the same time, thereby permitting the amounts being recorded in one counter to be accumulated to sub and grand totals in the other two.

The two hubs on the plugboard marked "CC" are the outlets for electrical impulses which will cause any counter to which either is wired to add "1". It is customary to use the excess

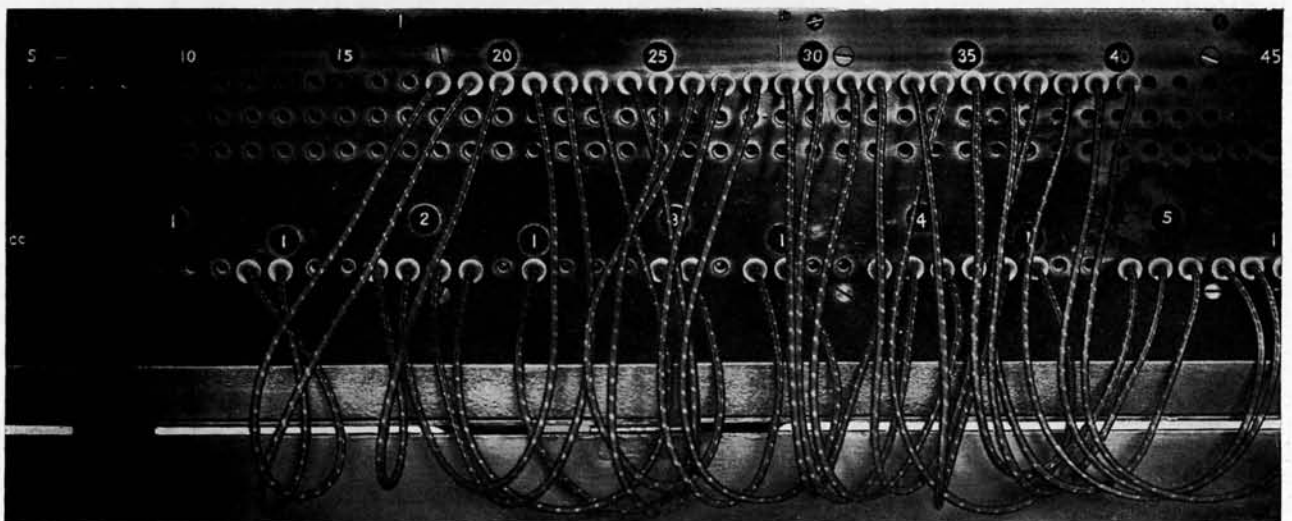

Type 92 Plugboard Wired for Adding

positions which appear in accumulating counters for card counting.

The preceding figure shows a plugboard with plugwires properly connecting the hubs representing certain columns of the tabulating card with those representing counter positions.

After having wired the plugboard of the machine, a card diagonally punched from 1 to 9 should be run through and read against the counter dials to determine whether the machine has been set up correctly. This should be done before running a group of cards through the machine to guard against the possibility of obtaining incorrect results due to improper wiring.

The next illustration shows a typical Sales Analysis card with the various punched data; Salesman—Quantity—Unit—Commodity—Selling Price—Cost, being recorded in counters one

operation of the counter. Group indication performs this function by breaking the adding circuit between the cards and the counter after the data from the first card of a group has been added in that counter.

Group Indicator

All electric tabulators are equipped with a group indicating device to provide for indicating in one or more of the regular counters the classification number of each group of cards which is passing through the machine. Group indication may be specified to operate on one or more of the first three counters. These counters may be arranged, also, to permit the use of some wheels for adding and some for indicating according to any split arrangement that may be specified.

When use is being made of the group indicator, a stop card must be placed after each

DAY	INVOICE NUMBER	CUSTOMER	TOWN	STATE	CLASS	SALES MAN	QUANTITY	UNIT	COMMODITY	SELLING PRICE	COST	FREIGHT	ACCOUNT
1	1	1	1	1	1	1	1	1	1	1	1	1	1
2	2	2	2	2	2	2	2	2	2	2	2	2	2
3	3	3	3	3	3	3	3	3	3	3	3	3	3
4	4	4	4	4	4	4	4	4	4	4	4	4	4
5	5	5	5	5	5	5	5	5	5	5	5	5	5
6	6	6	6	6	6	6	6	6	6	6	6	6	6
7	7	7	7	7	7	7	7	7	7	7	7	7	7
8	8	8	8	8	8	8	8	8	8	8	8	8	8
9	9	9	9	9	9	9	9	9	9	9	9	9	9

SALESMAN - QUANTITY - UNIT - COMMODITY - SELLING PRICE - COST

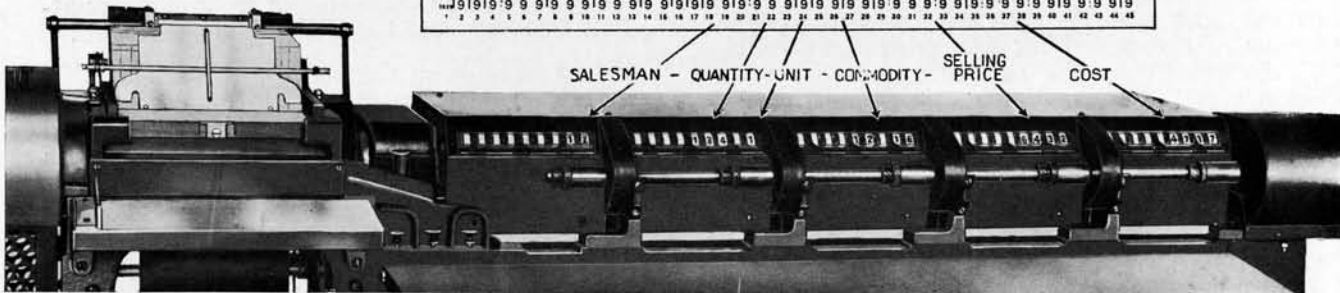

to five respectively. The plugging shown in the previous illustration is that necessary for obtaining this result.

It will be observed that two basically different types of information appear in the counters—some data are added and some are for group indication. The “group indications” serve to identify the classification of the group of cards being accumulated. Inasmuch as the counters were designed primarily for the purpose of adding data appearing in punched cards, it is obvious that if five cards for salesman 12 passed through the machine a total of 60 would be registered in counter one instead of the indication of Salesman No. 12—unless some special mechanism were provided to control the

group of cards being tabulated. When the same classification numbers appear regularly in recurring periodic tabulations, punched stop cards can be placed in their position by the sorting machine. In such cases the stop cards are placed in front of the regular cards on the initial sort. A sorting needle may be used for picking off each group when the stop cards are to be inserted by hand.

When the machine is stopped by a stop card, the figures appearing in the counters may be posted, after which the counters may be set to zero by closing the accumulating collars of the counters to be cleared and depressing the reset key. It is necessary to repeat this process upon completion of the tabulation of each group.

Counter Accumulating Collar

Each counter is equipped with an accumulating collar which permits the operator, after each group, either to set the counter to zero or to allow it to accumulate sub or grand totals. When the accumulating collar is engaged (to the right) as shown, it is in proper position to clear the counter to zero at a reset cycle.

the tabulation be arranged in the desired sequence and the necessary stop cards inserted between groups. If only totals by major and minor classifications are to be prepared, a single stop card should be placed after each minor group, and two stop cards after each major group. Each time the machine stops, the operator transcribes the minor totals and then

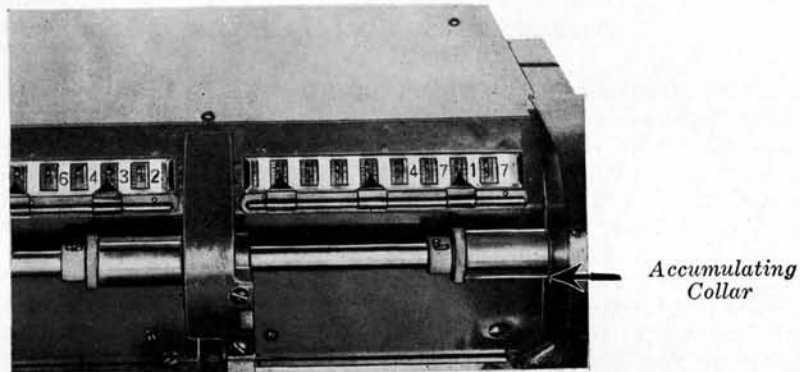

Counter Accumulating Collar—Collar Engaged

Reset Mechanism

The reset motor is located on a platform attached to the right end of the machine base. When the reset key is depressed this motor operates a shaft extending horizontally along the front of the counters.

The counter accumulating collars are positioned on the reset shaft and function in connection with it, as previously explained. At the completion of the reset cycle the machine will automatically start tabulating the next group of cards.

Operation

Cards may be tabulated for a single grand total or they may be tabulated according to groups and sub-classifications. If only grand totals are desired, wires for the quantities and amounts should be inserted in the proper column and counter hubs of the plugboard. The cards should then be joggled to even the edges and placed in the feed magazine—printed side toward the feed knives and the 9's at the bottom. The depression of the start key puts the machine in operation, but it is customary to close all the counter collars and depress the reset key before operating the machine to insure that all counters have been cleared to 0. When the last card has been tabulated, desired totals may be transcribed to the control record or report form.

If a tabulation by group classification is to be prepared it is essential that the cards for

depresses the reset key. Whenever the machine stops immediately following the resetting of counters, it indicates that a second stop card has appeared. This serves as a signal to the operator to copy the amounts and to close the collars of those counters accumulating major totals before depressing the reset key a second time.

In order to obtain indications and corresponding totals the plugboard must be properly wired for adding desired data and group indicating required symbols. Group indicating switches must be placed in the ON position for the counters in which classification data are to appear. Counter accumulating collars should be set so that group indications and minor totals will clear at each reset. Accumulating collars for counters containing major or grand totals should be open.

The tabulating operation can be conveniently controlled by a person seated at the writing board of the machine. From this position the counter totals can be readily seen and transcribed to report forms. Also, from this position, additional cards may be fed into the magazine hopper and removed from the stacker, and all operating keys and switches may be easily reached.

Special care should be taken in the setting-up and operation of the machine to insure accuracy of results and efficiency of operation. When a change from one set-up to another is being

made the main line switch should be turned off. Unnecessary plugboard wires should not be left in the machine. It will be impossible to obtain correct results from the machine if a partially inserted plug wire is permitted to hang loosely and touch the base or adjacent wires.

No more cards than can conveniently be removed with one hand should be allowed to collect in the card stacker. On long runs, totals should be transcribed after every two thousand cards to prevent having to retabulate all the cards in event of a mishap.

Automatic Control Tabulator (Type 93)

By 1914 the art of tabulating had been applied to so many fields of accounting that engineering development was directed toward the consolidation of many principles of operation that had been devised and proposed, and the construction of a machine which would more adequately meet the demands of a fully automatic bookkeeping and accounting system. One of the units which proved to be especially valuable was the Automatic Group Control. This device was incorporated in the development of the electric tabulator to produce the Automatic Control Tabulator.

Automatic Control

This machine is used in exactly the same manner as the Electric Tabulating Machine (Type 92) except that it is not necessary to use

stop cards. The electric automatic control with which this machine is equipped functions so that at the end of each group classification the machine stops automatically. The totals can then be posted from the counter dials. The chief difference in the appearance of this machine and that of Type 92 tabulator is in the feeding mechanism. The automatic control tabulator is "double decked"; that is, there are two sets of brushes in the machine to effect automatic control. The presence of this additional set of brushes increases the size of the feed.

By the use of the automatic control feature, it is possible to obtain an additional check of the accuracy of the arrangement of the cards being tabulated. Any card not located in its proper group causes a break in control and the counter used for group indication shows the

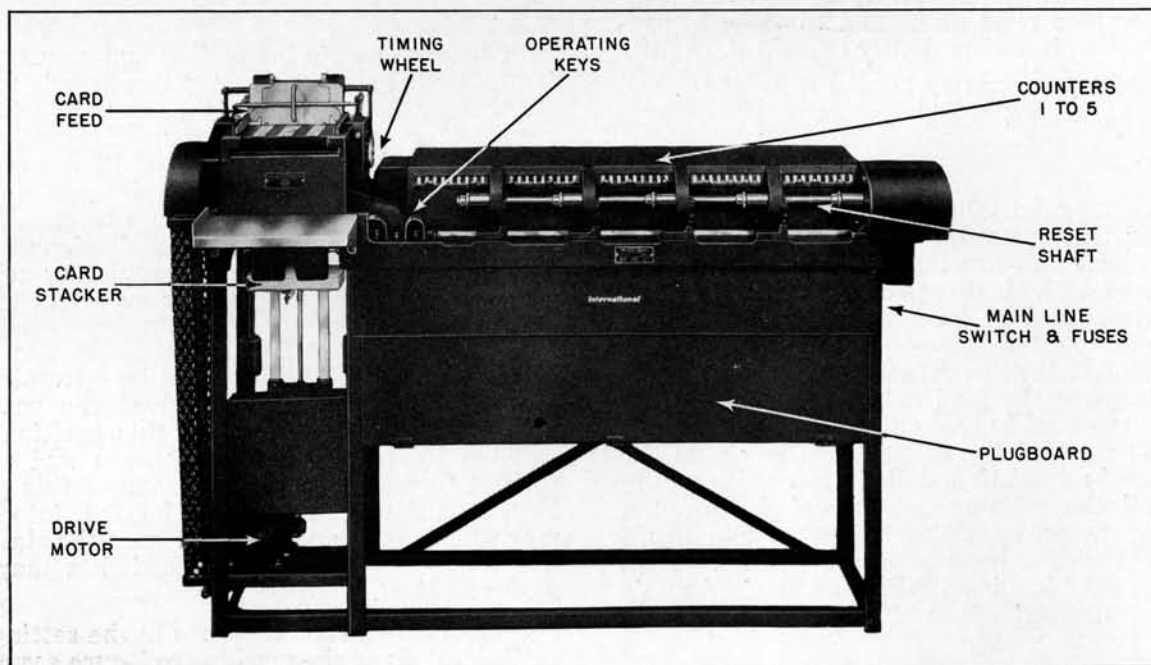

Automatic Control Tabulator—Type 93

classification in which the total should be included.

The upper set of brushes is called "Control Brushes" and the lower set, "Adding Brushes." Automatic control is effected by electrical comparing circuits being set up between these two sets of brushes.

As one card passes the lower brushes, any card immediately following it is in the corresponding position relative to the upper brushes. As long as the holes punched in those columns of the card wired for automatic control and being read by the lower brushes are identical with those being read by the upper brushes the machine will continue to run. When such punchings are not identical the machine breaks control and stops automatically, thus signalling the end of a group.

The Electric Automatic Control Tabulator is equipped with major and minor control and will function on two different group classification fields simultaneously. The machine automatically senses changes in either classification as it occurs.

Operating Keys

There are four operating keys on this machine: the usual start, stop, and reset keys, and a major-total reset key which is located at the right of the regular reset key.

If a control change occurs in a minor classification, the machine will come to a stop. Desired counter dials can be cleared and the machine automatically started by depressing the regular reset key. When a change occurs in a major classification, the machine will come to a stop but fail to reset by the use of the regu-

lar reset key. This gives the operator the signal, before depressing the major-total reset key, to engage the accumulating collar on the counter from which the major total is to be taken. The reset can only be operated from the major-total reset key when the major group changes. In other words, the machine must be reset from the regular reset key on each change of the minor group and only from the major-total reset key when the major group changes.

Plugboard

The plugboard illustrated is wired, or plugged, to tabulate the data shown on the typical sales analysis card illustrated. The machine is arranged to control on "Salesman." The position of the shunt plug is shunting out the six positions not being used.

Automatic Control Switch

It will be noticed that there is a switch on the plugboard marked "Auto Control." When this switch is to the *left* the control is operative and when it is set to the *right* the control feature becomes inoperative. When the switch is in the latter position the machine can be used as a Type 92 tabulator.

Group Indicating

The group indicating feature on this machine is somewhat more flexible than on the Electric Tabulating Machine. It is possible to add and indicate in a single counter at the same time if the total number of adding and indicating digits does not exceed eight. If this combined indicating and adding feature is used, the group indicating switch for the counter being so used must be Off, or to the right. In order to plug the machine for this feature it is

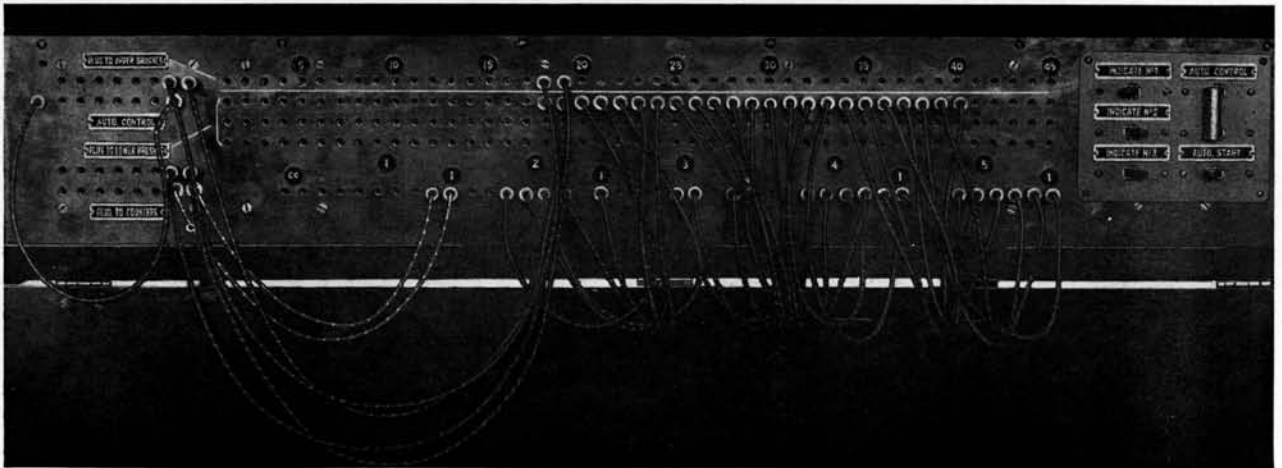

Plugboard of Automatic Control Tabulator

necessary to connect the indicating field from the desired lower brush plugboard hubs to No. 3 row of hubs in the control unit side of the plugboard and from No. 4 row of hubs to the counter hubs of the plugboard. The same sequence of plugging should be followed in the wiring of upper and lower brushes. The adding field should then be connected from the desired lower brushes to the remaining counter plugboard hubs.

It is important that the group indicating switch for the counter being so used, be to the right.

Plugging for Automatic Control and Group Indicating

The automatic control feature on this machine will function only where there is a punched hole from 9 to 0 in each column of the controlling field. The control will not operate on holes punched in the 11th and 12th posi-

tions; neither will it function on double punching nor on unpunched columns.

The chart illustrates plugging for major and minor control. Card columns 4-5-6 are plugged for major control and to indicate on the left side of counter No. 1. Card columns 11-12-13-14 are plugged for minor control and to indicate on the right side of No. 1 counter.

The positions of shunt plugs should be noted. When the major control feature is not being used the major shunt plug should be in its socket to the left of plugboard, otherwise the machine will not run. It should be noted from the figure that when the machine is wired to control on certain columns of the card, both the adding and control brushes corresponding to these columns are wired to the control unit.

Operation

The same general instructions stated for operating the Electric Tabulating Machine (Type 92) apply equally as well for running this machine.

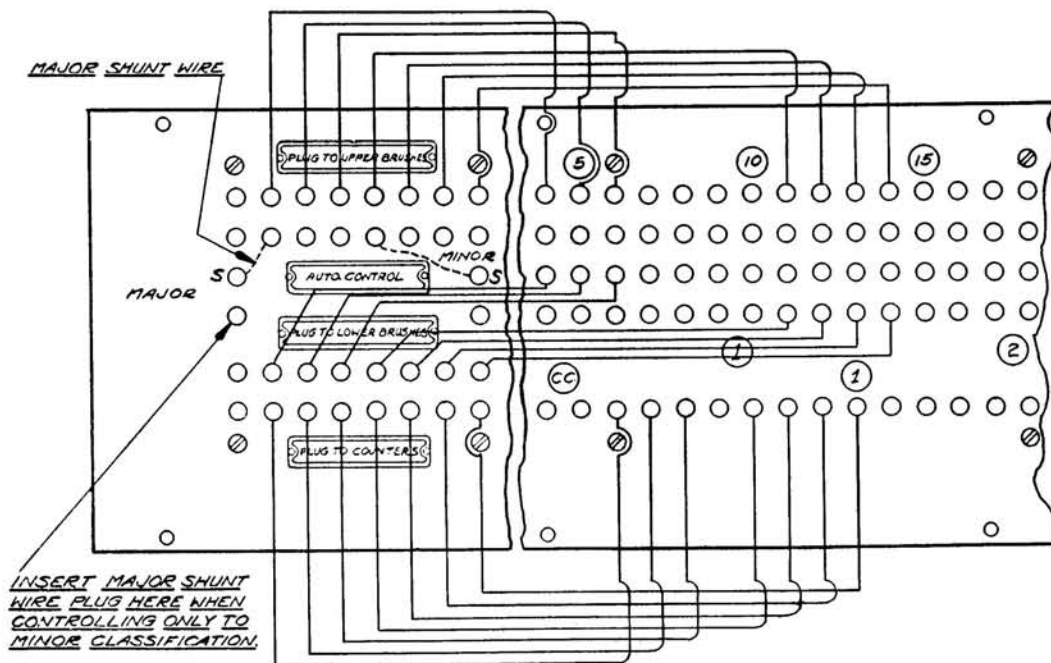

PLUGBOARD OF AUTOMATIC-CONTROL TABULATOR

Example of plugging of major-minor control. Card columns 4-5-6 plugged to major control and to indicate on left side of No. 1 counter. Card columns 11-12-13-14 plugged to minor control and to indicate on right side of No. 1 counter.

Electric Accounting Machine

A printing mechanism which is capable of automatically printing accounting documents and reports was developed simultaneously with the Automatic Control. The combination of these mechanisms resulted in the production of a printing tabulator known as the Electric Accounting Machine.

Prior to the introduction of this machine, the part played by tabulating machines ended with the appearance of totals in the counters. These totals had to be transcribed by hand. Sometimes this resulted in illegible entries or in outright errors—besides limiting the speed of the operation to the speed attainable in writing down the correct figures in the proper report columns. The printing mechanism thus carried forward the speed, economy, and precision only obtainable by purely mechanical operation, to the final stage of the accounting process.

The printing mechanism multiplied the uses to which tabulating cards and electrical accounting machine principles could be adopted. As a direct result, numerous and frequent

changes of design were incorporated in the machine to meet the wide variety of special problems which were encountered. These improvements have since been combined to produce newer standard models of accounting machines which contain all of the special features that have proven to be generally adaptable. Inasmuch as these recent models are fully described in other sections of this booklet, only the description of the features of the printing mechanism will be given here.

The printing unit of the Electric Accounting Machine, that may be actuated either directly from punched holes to list detailed information from each card or from totals accumulated in counters, is synchronized with the mechanism of the Automatic Control Tabulator previously described. It is used to indicate on the report form the classification data pertaining to each control group, to automatically transcribe totals of groups of cards to the reports in printed form, and to list the complete detailed information recorded on the punched cards.

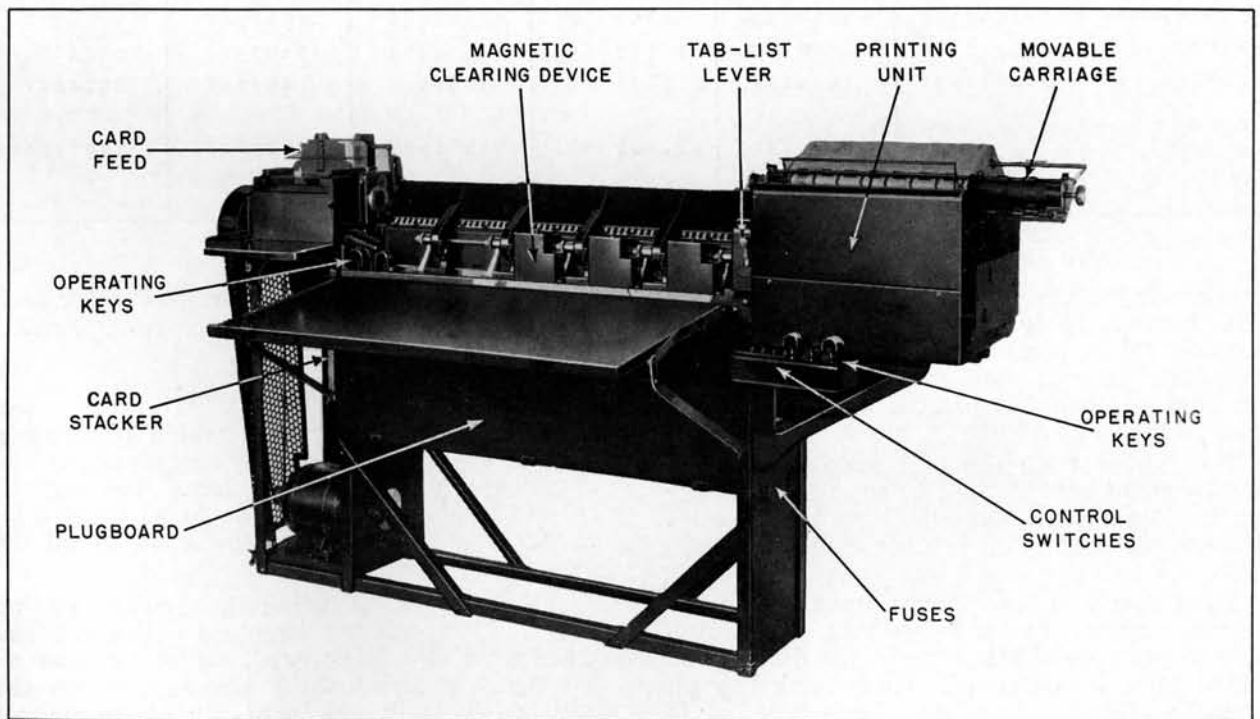

Printing Tabulator

Printing Capacity

The printing mechanism of the Electric Accounting Machine is built on the right end of the machine upon an extension of the base. It is composed of a single row of individual type bars arranged in groups of 10 termed "Print Banks." Five or seven banks of type have been provided for the five-counter Accounting Machine. The five-bank machine has five accumulating counters and five corresponding print banks. The five-counter seven-bank accounting machine, in addition to the five banks of type corresponding to the counters, has two banks of type forming the left portion of the printing mechanism which may be used only for indicating group classifications or detailed listing. These two banks of type bars are in no way connected with a counter and are therefore incapable of printing totals.

Paper Carriage

The carriage of the printing mechanism is similar in appearance to a typewriter carriage. It will accommodate individual sheets, rolls, or continuous folded forms up to 20 inches in width. Standard typewriter spacing is provided—six single spaces or three double spaces vertically to an inch. The position of a lever on the left of the platen controls the spacing. The advancing of report forms from one printing position to another is synchronized with the operation of the tabulating mechanism and is automatically performed.

The operation of the carriage is also controlled by a lever labelled TAB-LIST located at the left-front side of the printing unit. This lever when set to TAB advances the paper only after each group of cards has been tabulated and the resulting totals printed. When it is

LIST BANK NO. 1	LIST BANK NO. 2	COUNTER BANK NO. 1	COUNTER BANK NO. 2	COUNTER BANK NO. 3	COUNTER BANK NO. 4	COUNTER BANK NO. 5
1234567890	1234567890	12345678	12345678	12345678	12345678	12345678
2345678901	2345678901	23456789	23456789	23456789	23456789	23456789
3456789012	3456789012	34567890	34567890	34567890	34567890	34567890
4567890123	4567890123	45678901	45678901	45678901	45678901	45678901
5678901234	5678901234	56789012	56789012	56789012	56789012	56789012
6789012345	6789012345	67890123	67890123	67890123	67890123	67890123
7890123456	7890123456	78901234	78901234	78901234	78901234	78901234
8901234567	8901234567	89012345	89012345	89012345	89012345	89012345
9012345678	9012345678	90123456	90123456	90123456	90123456	90123456
123456789	123456789	1234567	1234567	1234567	1234567	1234567
		499999995*	499999995*	499999995*	499999995*	499999995*

Listing and Total Printing () Capacity*

The bar on the right end of each counter print bank is reserved for an asterisk to distinguish totals from detail listed items. All remaining bars of each counter bank and all ten bars of each list bank contain numerical type from 0 to 9.

The type bar on the extreme left of each counter print bank cannot be used for the listing of detail items. It is actuated only from counter totals to print the accumulated carry-over.

To properly design forms upon which accounting records are to be printed, it is necessary to pay special attention to the dimensions which must be observed. Each bank has an overall width of $1\frac{7}{8}$ inches. Each type bar is $\frac{5}{32}$ of an inch in width and the ribbon guides between banks each require $\frac{10}{32}$ of an inch.

set to LIST, the paper is advanced after each listing cycle as well as after each total printing cycle of the machine.

Type Bars and Their Operation

The numerical type with which printing is effected are arranged in the order shown in the upper section of the type bar. The desired type is positioned at the line to be printed by means of the teeth on the lower section of the bar.

In the listing operation the upward motion of the type bar is synchronized with the downward feeding of the card. Just as soon as the brush completes the circuit through the punched hole in the card, an electromagnet causes a stop pawl to drop in the notch corresponding to the hole of the card and the

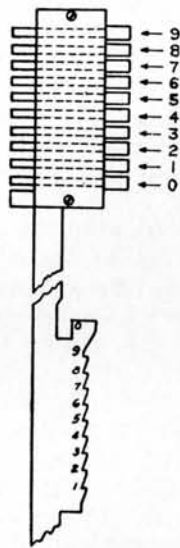
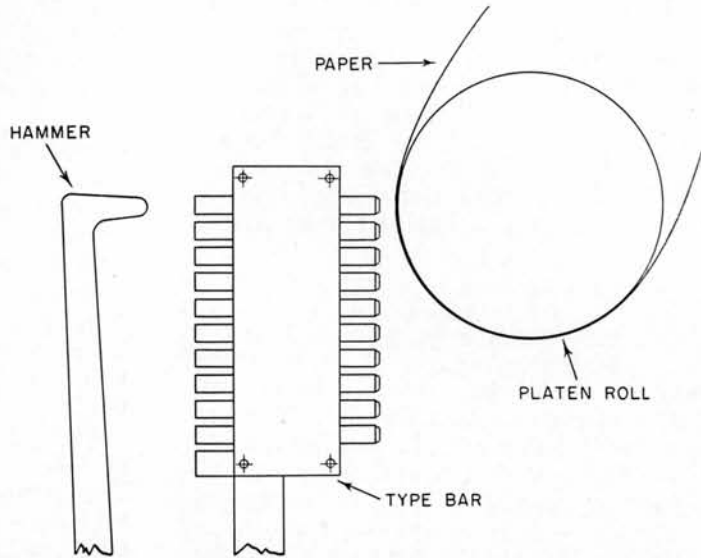

Diagram of Type Bar



Relative Positions of Type Bar and Platen

character to be printed. This arrests any further movement of that type bar and the desired character is printed.

The mechanism is so arranged that within the limits of each type bank, zeros print automatically to the right of any figure from 1 to 9 but not to the left of such figures. Whenever a significant digit appears in any position of a number other than the units position, all type bars to the right of the significant digit are stopped at the 0 position instead of moving up to the non-print position—unless they have been previously stopped for the printing of a significant digit.

After a card has been fed far enough down into the machine so that the brushes have passed over all of the positions of each column from 9 to 0, each of the type bars will have been

properly positioned for printing. The impression of the characters to be transcribed is accomplished as the rear of each individual printing type is struck by a hammer lever.

The general principles of printing totals are similar to those just described except that the cards stop feeding during the printing cycle and the type bars are synchronized with a mechanism for sensing the totals appearing in the counters.

Hammer Locks

Printing by individual type bars may be suppressed by the setting of hammer-lock levers. These devices are frequently used to eliminate the printing of asterisks except for the designation of major totals, and also for the elimination of the printing of 0's between groups of figures when more than one class of data is

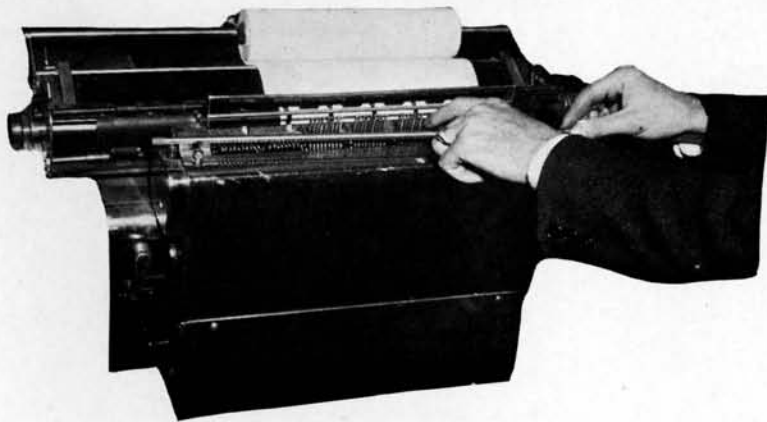

Setting Hammer Locks

recorded in a single print bank. The levers must be moved down to the horizontal position to make the type bar inoperative. Hammer-locks for positions to be printed must be vertical. For example, if it is desired to eliminate all the printing in banks 1 and 2 and the asterisks in banks 3 and 4, the corresponding hammer-locks are pushed down and held in place by the hammer-lock bar as shown in the figure.

Switches

Each additional feature incorporated in the accounting machine is controlled by a switch which may be used, when desired, to control the operation of any of these devices. The various results obtainable are revealed by a brief description of the switches and their uses.

Major Control. This switch when ON causes the machine to stop at the end of each group of cards which are similarly punched in the card field that has been wired for major control on the plugboard. When the switch is OFF the machine operates as though the Major Control had not been wired.

Magnetic Clearing Devices. The first printing tabulators were so designed that minor totals could be automatically printed and cleared from the counters; but at major totals the machine would stop. The stopping of the machine served as a signal to the operator to close the counter accumulating collar of the counter in which the major total appeared before depressing the reset key to clear the counter and restart the machine. The introduction of magnetic clearing devices eliminated the necessity of this manual operation. Each clearing device consists of an electromagnet (located in a small box in front of the counter which it ac-

tuates) whose armature operates a lever that mechanically engages the counter collar at each major reset. Its operation is controlled by a switch situated on the top of the box.

When the magnetic clearing device is to be operative the counter accumulating collar should be disengaged and the switch turned ON. The operation of these devices merely eliminates the necessity of manually resetting to zero the counters carrying major totals.

Minor Control. The operation of this switch is parallel to that of the major control switch. When both of these switches are OFF, the machine will accumulate the grand totals of all cards without stopping for sub-classifications.

Tab-List. The lever marked TAB-LIST is a switch which performs several functions. When turned to LIST it changes the rate at which cards are fed to the listing speed, and engages the printing mechanism to the main shaft of the machine so that the type bars may print from each card that is fed.

When the switch is set at TAB, the machine operates at the tabulating speed of 150 cards a minute and the printing mechanism is rendered inoperative except for total printing.

The lever may be moved by pulling it forward and swinging it to the desired position. Care should be taken never to change this lever while the machine is running.

Total Print. This switch is provided to make the printing mechanism for transcribing totals operative or inoperative. As a general rule, it is always in the ON position. It is turned to the OFF position only when totals appearing in the counters as a result of a tabulation are to be cleared and a printed record is not desired.

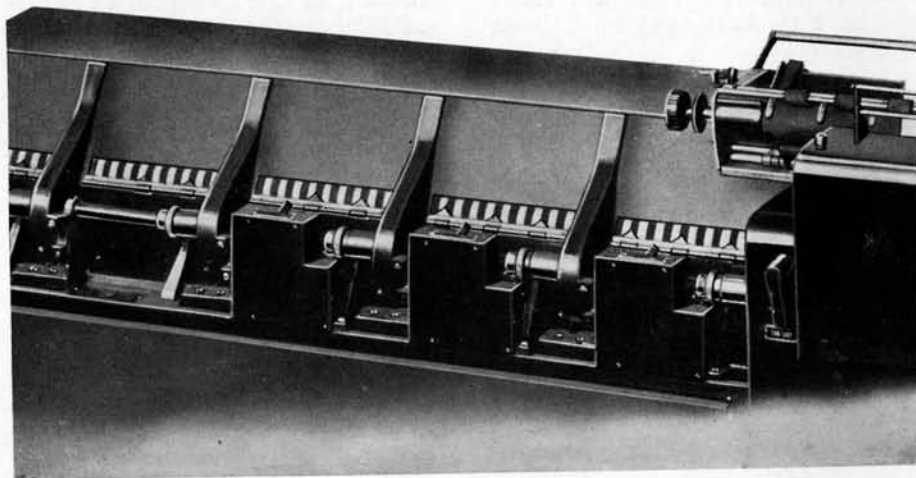

Magnetic Clearing Devices

Progressive Totals. Special switches are provided for each counter to permit the transcription of progressive totals to printed reports. The depression of the reset key will transcribe progressive totals from all counters that have these switches turned to ON.

Counter List Switches. Individual list switches are furnished for each counter. When such a switch is turned OFF, only the counter total can be printed. When it is turned ON, the machine will print the data introduced into the counter from a tabulating card—subject to further control by the TAB-LIST switch. If the TAB-LIST lever is set to TAB, only the data appearing on the first card of a group will be recorded. If this lever is set to LIST, the data from each card will be printed.

Inasmuch as the listing is accomplished as the first card of a group is fed into the machine, and total printing is effected after the last card of the group has been added, attention should be given to the setting of switches to prevent total printing over listed detail. Whenever the TAB-LIST lever is set to TAB and a counter accumulating collar is engaged for a certain counter, the LIST switch for that counter should be OFF.

Auto Reset. Because of the fact that the automatic control feature results only in the stopping of the machine at the end of each control group, a special mechanism is provided which results in the automatic printing of totals and clearing of the counters. When the Auto Reset

switch is ON these operations are automatically performed; when it is OFF, the machine stops in the same manner as the Automatic Control Tabulator. This switch is set in the OFF position when listed reports are being prepared which require inserting a separate page for each minor control group.

Auto Start. The Auto Start switch as its name implies causes the machine to start automatically after each resetting. When it is turned to OFF, it is necessary to depress the Start Key to start the feeding of cards.

Summary

The evolution of Accounting Machines has been briefly described in order to present a picture of the stages by which automatic mechanical devices superseded less automatic operating routines. The machines of necessity have become more complex; but the record-keeping routines have conversely become simpler.

The descriptions of the features of each machine that marked a definite forward step in the Art of Electric Accounting may be referred to in analyzing the functions of each part of modern machines. The Accounting Machine of today is in reality a machine composed of many distinct smaller semi-automatic units that have been conveniently combined into a single automatic, all-purpose accounting machine. If one is familiar with the principles of operation and use of each major feature of automatic tabulation, any detail variations encountered may be readily understood.

Special Devices for Accounting Machines

The various models of International Electric Accounting Machines in current use have been adapted to many different types of record-keeping routines. This wide range of application was made possible by the development of special devices and attachments to facilitate the automatic preparation of special reports and documents.

Details concerning the operation of these devices will not be discussed here; but the features of the most important units are briefly described below.

Automatic Bill Feed

The Automatic Bill Feed is an attachment to the print unit of Electric Accounting Machines which automatically feeds and ejects single sheets or card forms. It consists of a magazine for blank forms, a special platen, a stacker, and a mechanism for feeding and ejecting the forms.

Automatic Major Control Stop

Numerical machines with magnetic clearing devices ordinarily continue in operation after a major control change. An automatic stop can be provided to cause the machine to stop either before or after taking a major control total, or both. (A similar stop can be provided for intermediate control on Type 297 machines, and Type 285 machines which are so equipped.)

The stop before taking totals is necessary when it is desired to shift the carriage for printing the total. The stop after taking the total is useful when it is desired to change sheets for major control groups.

Auxiliary Card Counter

All tabulators and accounting machines can be equipped with one or two Veeder counters for the following purposes:

1. To count all cards passing through the machine by plugging directly from the card count hub to the TCC hub on the plugboard.
2. To count the number of cards in different classifications by plugging the card count impulse through a class selector to the TCC hub.
3. To count the number of minor control groups by plugging the card count impulse through the group indicator to the TCC hub.

The Veeder counter has six positions allowing for a total count of 999,999.

Card Feed Stop

The automatic card feed stop may be installed on accounting machines to prevent the machine

from running out of cards and printing a total before the end of a control group. This device functions when about five cards remain in the hopper, thus permitting the operator to supply more cards.

Complement Total Suppression Device

The Complement Total Suppression Device is used to suppress the printing of complement totals from adding counters. It is permanently attached to one or more adding counters and controls the printing of totals in the respective print banks. When a "9" appears in the last magnet controlled adding wheel to the left in the counter, the counter is cleared but the printing of the total is suppressed.

Consecutive Number Control Device

The consecutive number control device causes the Electric Accounting Machine to indicate those numbers which are missing from a consecutive list, by printing a symbol opposite the first line after the break in sequence.

The missing number indication is usually printed from the asterisk bar, the symbol being placed in the "1" position. Thus, the missing number symbol does not interfere with either the asterisk or the credit symbol printing.

Continuous Form Feed Device

The Continuous Form Feed Device consists of the Line Finding Insert Device, described elsewhere, together with a stand arranged with shelves and paper guides for both blank and printed manifold sheets. When the shelves and paper guides are required, the order must specify the continuous form feed device.

Demountable Type Bars

Demountable type bars provide a means for securing flexibility in the printing of symbols and special characters without permanently changing the type on those bars so arranged. The bars are designed so that clips of type can be placed in the bars by the operator quickly and easily.

The demountable type bar consists of two separate units—a special bar, split to hold casings of type, and the casing or clip of type to be inserted in the bar. A clip of type consists of ten characters of type which are fixed within a casing and cannot be removed or changed. However, the type within a casing may be of any specified characters or symbols, and in any arrangement desired.

The type is changed by pressing a latch at the top of the bar and spreading the bar to

allow the clip of type to be removed and replaced with another clip. The type is then locked solidly in place by releasing the latch.

Fractions

Numerical and Alphabetic Accounting Machines can be equipped for the handling of fractions when they are specified. The fractions which are available for all types of machines are:

$$\frac{1}{2}, \frac{1}{3}, \frac{1}{4}, \frac{1}{5}, \frac{1}{6}, \frac{1}{8}$$

Intermediate Control

Type 285 Accounting Machines can be equipped with intermediate control in addition to the major and minor controls furnished as standard. The addition of intermediate control provides for securing three automatic classes of totals instead of two.

Line Finding Insert Device

The line finding insert device is a special type of quick insert device which is used to secure efficient operation with continuous forms.

The insert device is set for the length of the form to be run and for the first printing line on the sheet. As each line is printed, the insert device steps forward one position. When the printing of each sheet is completed—which may be either when the sheet is full or when the control changes—the insert device is used to space over the heading of the next sheet, stopping at the first printing line.

The insert device is furnished in two sizes, one of which will accommodate any length form up to 11", and the other up to 18". The length of the form must be a multiple of $\frac{1}{6}$ " in either case.

Pre-Indication Device

The pre-indication device is a special internal wiring arrangement for numerical and alphabetic Electric Accounting Machines which makes possible the listing of the control number of a group of cards **before** that group enters the adding brushes for printing. Pre-indication is accomplished by listing the control information from the control (upper) brushes instead of from the add (lower) brushes. Such an arrangement is particularly advantageous for ledger posting operations and for summary punching operations which involve the changing of master cards according to control group changes.

Single Card Total Suppression Device

The single card total suppression device is employed for the purpose of improving the appearance of tabulations in which single card groups are of frequent occurrence. This device eliminates the printing of the total when a single card has registered, thus avoiding the appearance of a double printing of the same item.

The speed of the machine remains unchanged by the addition of this device, since it spaces during the time in which it would ordinarily be printing the total. Asterisks are not printed when the total is suppressed but may be printed opposite any printed total.

Split Column Device

It is sometimes necessary to use two parts of a single card column for different purposes. In this event, accounting machines can be arranged to operate as though the punching were in separate columns of the card. For example, year can be punched in the same column with the first digit of month, and both can be indicated separately, as illustrated.

Split Counters—Adding Only

Where an adding counter is used for the purpose of securing totals of two or more fields, it is sometimes desirable to arrange it so that the total from one part of the counter will not carry over into the other part. This arrangement can be made permanently by installing a special carry-lever between the two parts of the counter.

However, if the counter is also to be used for other work, where the counter as a whole is required, a carry-lever lockout can be employed as a means of either preventing or allowing a carry over as desired. This device may be permanently installed between any two positions of a counter.

Print Banks—Zero Splits

The use of the special carry lever or the carry-lever lockout device does not affect the operation of the print bank, which will normally print zeros between the totals. Zeros between totals can be prevented from printing by making a permanent split between the type bars by removing the zero pawl. This will affect the operation of the print bank for use as a single unit, in cases where a carry-lever lockout is used, since zeros will not be printed automatically to

the right of the bar from which the zero pawl has been removed.

Total Transfer Device

The total transfer device provides for the printing of totals in a print bank other than that which is normally associated with the

counter in which the total is accumulated. The total is printed on the reset cycle for which the counter dial is set.

For example, a major control total may be automatically printed in the same bank with the minor control totals without shifting the carriage.